

ML7999B Universal Direct Coupled Actuator

PRODUCT DATA



APPLICATION

ML7999B Universal Direct Coupled Actuator provides 100 lb-in. torque, 4 to 20 mA control input to control combustion air dampers and modulation valves. The actuator includes precision drive shaft control and integral power supply capable of direct line voltage connection.

IMPORTANT

The ML7999B Universal Direct Coupled Actuator is not intended for use in combustion applications where both the fuel supply and air supply are modulated to maintain proper combustion.

FEATURES

- Universal power supply input (100 to 240 Vac [+10%/-15%], 50/60 Hz).
- Programmable actuator stroke against 4 to 20 mA input.
- 100 lb-in. (11.3 Nm) torque.
- Separate wiring compartment between line voltage power wiring and low voltage control.
- Direct coupling shaft interface mounting.
- Couples directly to a 1/2 in. (13 mm) round or square shaft with no additional parts required.
- Couples directly to round or square 5/16 in. (8 mm) and 3/8 in. (9 mm) shafts using available self-centering shaft reduction accessories.
- Shaft coupler assemblies available for shafts larger than 1/2 in. (9/16 in., 5/8 in., and 3/4 in.).
- Bracket Accessory Kit available for mounting to Honeywell V51 Butterfly Gas Valves.
- Visual indication of actuator position.
- NEMA 4 rating with optional weatherproof kit.

Contents

Application	1
Features	1
Specifications	2
Ordering Information	2
Installation	3
Wiring	4
Operation	6
Programming	6
Checkout and Troubleshooting	7



SPECIFICATIONS

Model:

ML7999B Universal Direct Coupled Actuator. Medium torque electronic actuator with a precision drive shaft control and integral power supply capable of direct line voltage connection.

Dimensions: See Fig. 1.

Electrical Ratings:

Power Input: 100 to 240 Vac +10% -15%, 50/60 Hz.
Maximum Power Consumption: 15 VA.

Temperature Range:

Ambient: -40°F to +140°F (-40°C to +60°C).
Storage: -40°F to +150°F (-40°C to +66°C).

Humidity Range (at 95°F [35°C]): 5 to 95 percent relative humidity, noncondensing.

Vibration: 0.0 to 0.5g continuous (V2 level).

Control Signal (see Fig. 9):

Requires a 4 to 20 mA current source.
Minimum signal differential (zero to open): 3 mA.
Maximum signal range: 3 to 22.5 mA.
Minimum programmed angular span (modulation range): 13 degrees.

Actuator Stroke: 95° nominal ± 3°, mechanically limited.

Output Hub Position Accuracy: ±0.1°.

Torque Ratings at Rated Voltages:

Lift and Hold Minimum: 100 lb-in. (11.3 Nm).
Breakaway Minimum: 100 lb-in. (11.3 Nm).
Stall Minimum: 100 lb-in. (11.3 Nm).
Stall Maximum: 150 lb-in. (17 Nm).

Actuator Design Life (at 100 lb-in.):

Full-Stroke Cycles: 100,000 minimum.
Repositions: 2,000,000 minimum.

Actuator Timing (90° Travel):

Standard: 24 to 30 seconds.

Derated Cold-Start Timing (from -40°F to -20°F (-40°C to -29°C): 150 seconds maximum.

Noise Rating: 55 dBA maximum at 1m during normal operation.

Mounting:

Mounts directly on 1/2 in. (13 mm) round or square shaft. With proper accessories, mounts to 5/16 in. and 3/8 in. (8 mm, 10 mm) round or square shafts; 9/16 in., 5/8 in., and 3/4 in. (14 mm, 16 mm, and 19 mm) round shafts.

IMPORTANT

Tighten hub setscrews to a torque of 60 lb-in. ±10 lb-in.

Position Indicator: Visible with cover on device.

Approvals:

Underwriters Laboratories Inc.: File No. 174H.

FM: Pending.

CSA: Pending.

Enclosure: NEMA2.

Accessories:

201391 Shaft Adapter for 3/8 in. round or square shaft.
32003167-001 Shaft Adapter for 5/16 in. round or square shaft.
32003168-001 Shaft Adapter for 3/4 in. diameter round shaft.
32003168-002 Shaft Adapter for 5/8 in. diameter round shaft.
32003168-003 Shaft Adapter for 9/16 in. diameter round shaft.
32003396-001 V51 Mounting Bracket for 1-1/2 in. and 2 in. valves.
32003396-002 V51 Mounting Bracket for 2-1/2 in., 3 in. and 4 in. valves.
32002935-001 ML7999 Weatherproof Kit Enclosure: NEMA3/IP54.

ORDERING INFORMATION

When purchasing replacement and modernization products from your TRADELINE® wholesaler or distributor, refer to the TRADELINE® Catalog or price sheets for complete ordering number.

If you have additional questions, need further information, or would like to comment on our products or services, please write or phone:

1. Your local Home and Building Control Sales Office (check white pages of your phone directory).
2. Home and Building Control Customer Relations
Honeywell, 1885 Douglas Drive North
Minneapolis, Minnesota 55422-4386

In Canada—Honeywell Limited/Honeywell Limitée, 35 Dynamic Drive, Scarborough, Ontario M1V 4Z9.

International Sales and Service Offices in all principal cities of the world. Manufacturing in Australia, Canada, Finland, France, Germany, Japan, Mexico, Netherlands, Spain, Taiwan, United Kingdom, U.S.A.

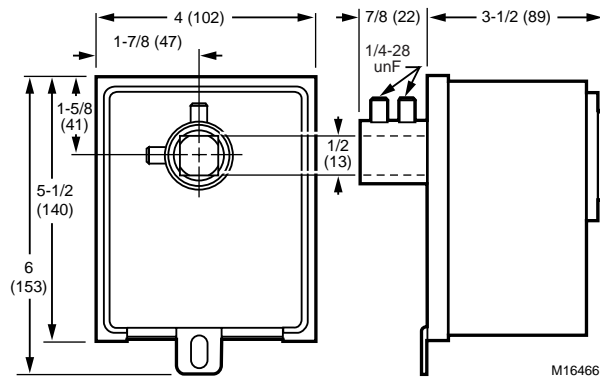

Fig. 1. ML7999 dimensions in in. (mm).

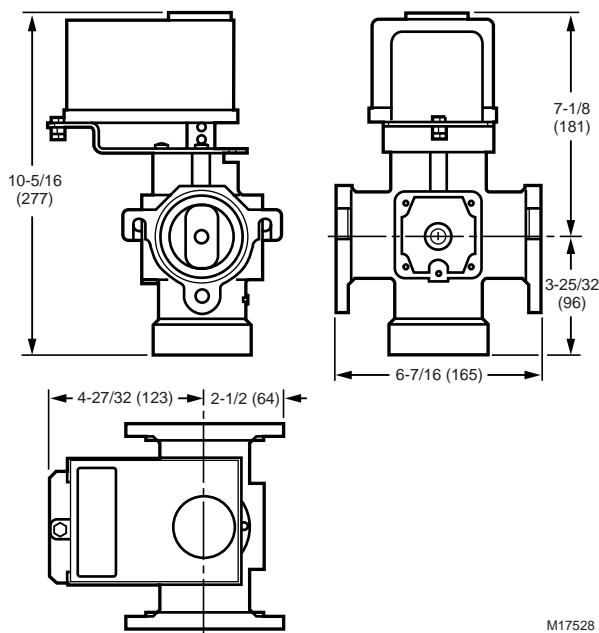

Fig. 2. V5197A Firing Rate Gas Valve, with mounting bracket (included) and ML7999 Actuator (not supplied), dimensions in in. (mm).

INSTALLATION

When Installing this Product...

1. Read these instructions carefully. Failure to follow them could damage the product or cause a hazardous condition.
2. Check the ratings given in the instructions and on the product to make sure the product is suitable for your application.

3. Installer must be a trained, experienced service technician.
4. After installation is complete, check out product operation as provided in these instructions.

WARNING

Fire or Explosion Hazard.
Can cause property damage, severe personal injury, or death.
Tighten the hub setscrews to a torque of 60 lb-in. (7 N•m).

WARNING

Electrical Shock Hazard.
Can Cause serious injury or death.
Disconnect power supply before installation.

Location

CAUTION

Actuator Damage Hazard.
Deteriorating vapors and acid fumes can damage the actuator metal parts.
Install actuator in areas free of acid fumes and other deteriorating vapors.

Mounting ML7999 Actuator

The actuator mounts on a 1/2 in. horizontal or vertical shaft. Using the self-centering shaft reducer (included), the actuator can be mounted on a 5/16 in. shaft. For shafts larger than 5/16 in., adapters are available.

CAUTION

Equipment Damage Hazard.
Lateral forces on actuator hub will damage actuator.

Ensure actuator is mounted with shaft centered in actuator hub.

1. Place the actuator over the shaft, see Fig. 2.
2. Position and seat the actuator.
3. Rotate the shaft to match the actuator position.
4. Install the mounting bracket accessory (not included), if needed. See Fig. 3.
5. Partially tighten hub setscrews to ensure actuator seats firmly against mounting bracket with shaft centered in hub.
6. Tighten the anti-rotation bolt to the torque recommendation for the selected bolt/nut.
7. Tighten the hub setscrews against the shaft to a torque of 60 lb-in.

Mounting the ML7999 Actuator on V5197A Firing Rate Gas Valve.

⚠ WARNING

**Explosion Hazard and Electrical Shock Hazard.
Can cause explosion, serious injury or death.**

1. Turn off gas supply before starting installation.
2. Disconnect power supply for valve actuator before beginning installation and wiring. More than one disconnection can be involved.
1. Attach the mounting bracket for the ML7999 Actuator (supplied with the V5197 Valve) in the position that best suits the valve location, access space and wiring requirements.
2. Place the short end of the V5197 valve drive stem in the top of the V5197 Valve drive so that the rectangular portion of the drive stem is inside the valve drive.
3. Mount the ML7999 Actuator on the V5197 Valve and secure the actuator to the mounting bracket with the supplied screws.
4. Wire the ML7999 Actuator per the instructions in the Wiring section.
5. Restore power to the system.

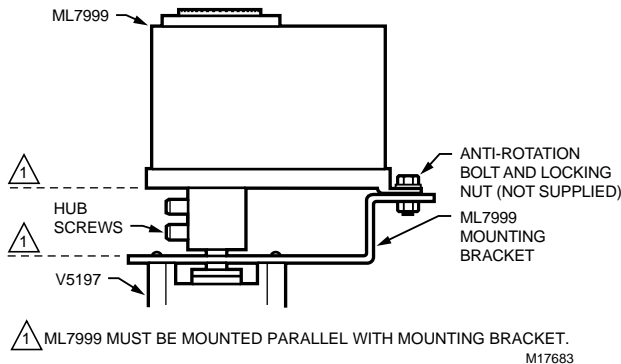

Fig. 3. Mounting the ML7999 on the V5197 Valve.

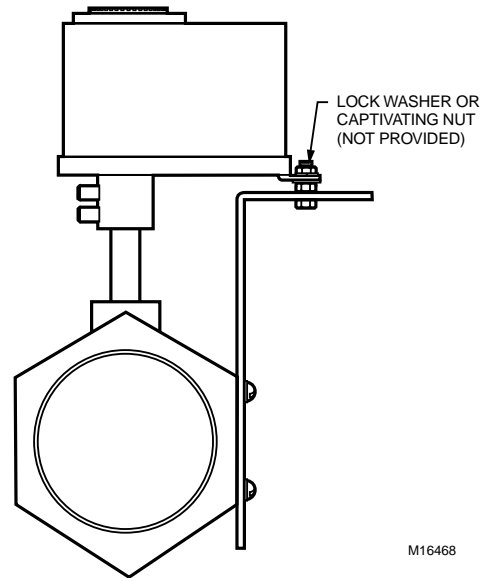

Fig. 4. Mounting ML7999 with mounting bracket accessory.

WIRING

⚠ WARNING

**Electrical Shock Hazard.
Can cause serious injury or death.
Disconnect power supply before installation.**

All wiring must comply with local electrical codes, ordinances and regulations. The ML7999B is designed for use with a Class 2 power supply for the 4-20 mA controller.

Preparation

Use OEM-supplied 1/2 in. conduit connectors in the low- and line-voltage base openings; the motor has separate line- and low-voltage wiring compartments.

Wiring Procedures

IMPORTANT

Device must be hardwired.

1. Remove the cover from the actuator.
2. Pull back the snap-locks while opening the low-voltage compartment. See Fig. 5.
3. Wire the low-voltage circuit to the 4-20 mA controller. See Fig. 6 for typical wiring connections.
4. Close the low-voltage compartment.
5. Wire the line-voltage circuit. See Fig. 6 for typical wiring connections.
6. Replace the cover on the actuator.

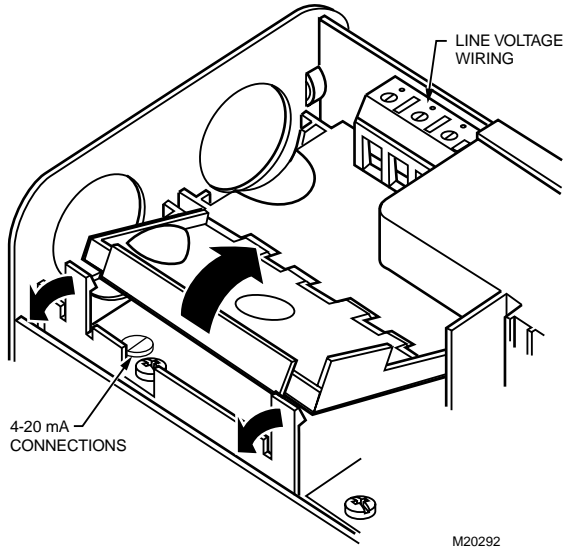

Fig. 5. Opening ML7999B low-voltage wiring compartment

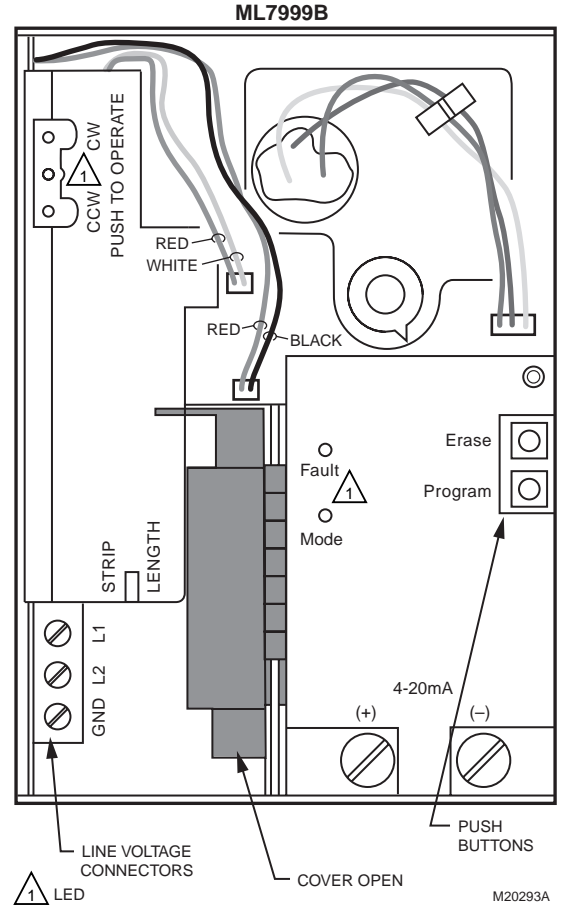

Fig. 6. Interior layout of ML7999B.

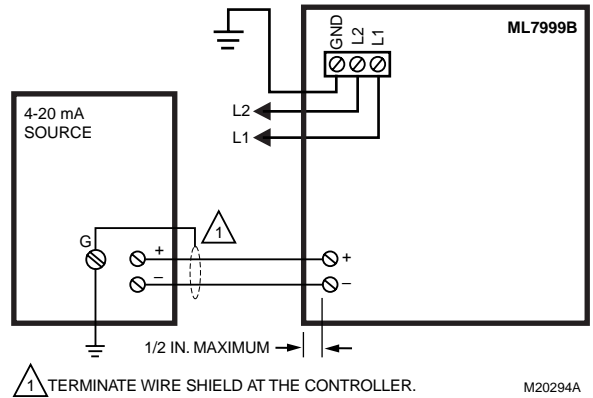

Fig. 7. Typical ML7999B wiring.

OPERATION

The ML7999B Universal Direct Coupled Actuator may be used to operate a variety of applications, including HVAC and combustion, or any other application requiring up to 100 lb-in. torque. The actuator incorporates a unique and simple software algorithm to set up the stroke of the actuator, based as a function of a 4-to-20 mA input controller.

WARNING

Explosion Hazard.

Can cause severe injury, death or property damage.

Do not use the actuator in non-supervised fuel-air ratio control systems or in other hazardous installations unless a fail-safe control system is also present. The ML7999B is not a safety rated device.

The actuator has a position indicator that shows shaft position. As the indicator moves with the shaft, it provides an angular representation of the shaft position.

IMPORTANT

When the cover is removed and replaced, the position indicator will not operate until manually rotated clockwise to engage it. An audible click indicates the position indicator is engaged.

NOTE: While installing the actuator, the hub can be manually driven using the push buttons located under the cover. The buttons are labeled CW and CCW. To use them, the only required wiring connections are L1, L2, and GND.

A momentary push and release of the button will result in the actuator shaft moving 0.1 degree in the direction of the button pushed. Pushing and holding the button will cause the actuator shaft to move in the direction of the button pushed for as long as the button is held in or until the shaft reaches the end of travel in the direction of the button pushed.

NOTE: See Table 1 for actuator manual interface blink pattern.

Table 1. Actuator manual interface blink pattern.

LED	Meaning
Fast Blink	Actuator unconfigured.
Slow Blink	Actuator configured.
Steady On	Actuator has failed.

PROGRAMMING

4 to 20 mA Configurable Actuator Interface (Fig. 8)

The MODE LED prompts the user through the required steps to configure the actuator interface. The operator shall use the actuator manual movement keys (upper left) to advance the actuator to the appropriate positions. The user must press and hold the interface card push buttons until the user notes a fast flash followed by a solid on condition in order for the command to be acknowledged.

Upon powering, an unconfigured actuator will come up with a 5-flash blink pattern on the green MODE LED and with the green actuator LED flashing fast. If this does not occur, see Erasing Actuator Configuration instructions, below.

Any time an error occurs, you may receive a fault blink code from the fault LED. See Programming Fault Codes (table 3) or Operating Fault Codes (Table 4) for details. Press and hold both ERASE and PROGRAM keys to clear the condition after making the directed correction. The actuator will automatically clear and attempt a re-start 60 seconds after the occurrence of a lockout.

MODE LED Programming Sequence (Fig. 9).

5-Flash

Move the actuator to the desired CCW or CW endpoint of the system (valve or damper). Press the PROGRAM button until the programming sequence is noted.

4-Flash

Move the actuator to the desired CW or CCW endpoint of the system (valve or damper). Press the PROGRAM button until the programming sequence is noted.

3-Flash

Move the actuator to the desired maximum or minimum modulation position with appropriate current source value to lock that endpoint of the modulation range. Press the PROGRAM button until the programming sequence is noted.

2-Flash

Move the actuator to the desired minimum or maximum modulation position with appropriate current source value to lock that endpoint of the modulation range. Press the PROGRAM button until the programming sequence is noted.

1-Flash

Firing rate interface is fully configured. The actuator manual interface LED changes from a fast to a slow flash rate.

Erasing Actuator Configuration

The actuator may be erased one step at a time. To bring a configured actuator to an unconfigured state, press and hold the ERASE key until the programming sequence is acknowledged; repeat four times.

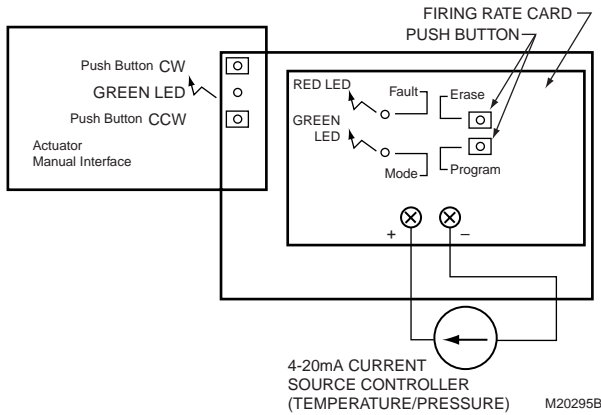

Fig. 8. 4 to 20 mA configurable firing rate interface.

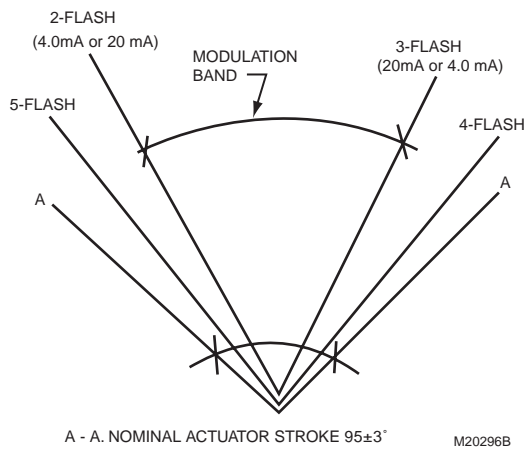

Fig. 9. MODE LED programming sequence.

CHECKOUT AND TROUBLESHOOTING

Checkout and Troubleshooting

If the actuator does not operate properly during Checkout, perform the following troubleshooting steps. Perform these steps before replacing the actuator:

1. Check the actuator label to make sure the power and control signal requirements are correct for the application.
2. Check for the presence of 120-240 Vac at the actuator (L1) and (L2) connections when the actuator should be driving. If the voltage is not present or is low, check the power supply.
3. Ensure actuator stroke matches stroke of damper or valve.
 - a. Remove the cover.
 - b. Press the button labeled CW. The actuator should drive the device clockwise.
 - c. Press the button labeled CCW. The actuator should drive the device counterclockwise.
4. If the actuator operates properly, check the controller for proper input signals.
5. If the actuator does not drive, remove power, disconnect the actuator hub, and try to turn the shaft of the valve or damper clockwise and counterclockwise. If the shaft turns freely throughout the 90-degree stroke and the actuator is installed properly, replace the actuator.
6. If the valve or damper shaft does not turn freely for the full 90 degrees, check for binding. If necessary, adjust mounting to prevent binding.
7. If the valve or damper shaft does not turn freely, fix or replace the device.
8. If the valve or damper shaft turns, reconnect the actuator and line voltage wiring and drive the actuator hub clockwise and counterclockwise. If the actuator does not drive, replace the actuator.
9. If the actuator and device shaft turn freely, remount the actuator to the device according to instructions in the Installation section. Make sure the actuator does not bind and that the actuator and device are both at the same clockwise or counterclockwise end stop when assembled. Hook up the wires and repeat the checkout and troubleshooting procedures.

The following tables and descriptions of the ML7999B can be used to assist in the checkout and troubleshooting of the device.

Table 2 describes the operation of the Erase and Set (Program) push buttons.

Table 3 describes the error codes that can occur during the programming of a point. The point is not saved. The error must be corrected prior to setting (programming) the point. The fault (red) LED will continue to flash this error code.

Table 4 describes the lockout fault codes.

Table 2. Erase and Set (Program) Push Button Operation .

Push Button	State	Action	MODE LED
Erase	Pressed and held for less than three seconds, then released.	None	Fast steady blinks while the button is held. When the button is released, the LED will resume flashing the current device status.
	Pressed and held for longer than three seconds, then released.	Change to the previous point programmed when the button is released. If the current point to be programmed was the first limit, then all configuration data is set to zero (factory) and the device is reset.	Fast steady blinks for three seconds, then steady On while the button is held. After button is released, the LED will resume flashing the current device status.
Program	Pressed and held for less than three seconds.	None	Fast steady blinks while the button is held. When the button is released, the LED will resume flashing the current device status.
	Pressed and held for longer than three seconds.	Attempt to program the current limit position and/or firing rate values into nonvolatile memory. If the values are accepted, the device will transition to the next state and flash the MODE LED appropriately. If the values are unacceptable, the device will remain in the current state and the Fault LED will flash the corresponding user error code.	Fast steady blinks for three seconds, then steady On while the button is held. After button is released, the LED will resume flashing the current device status.
Erase and Program	Pressed and held for less than three seconds.	None	Fast steady blinks while the button is held. When the button is released, the LED will resume flashing the current device status. If there is a fault present, the MODE LED will be Steady On. The Fault LED will be fast steady blinks.
	Pressed and held for longer than three seconds.	Erase an existing nonvolatile lockout condition, reset the device and attempt to run. All configured data remains.	Both LED steady On because lockout condition is present.

User Error Code (Table 3)

The user error code is indicated by the blinks and flashes of the LED. All codes consist of two digits. The tens' digits are indicated by a series of slow blinks while the ones' digits are

indicated by a series of short flashes after the slow tens' digit. For example, user error code 64 consists of six slow blinks followed by four fast flashes.

Table 3. Programming Error Codes .

MODE LED	Error Code	User Error Description	Corrective Action
4 Blinks (Setting second travel limit)	12	The actuator stroke limits are too close. The actuator stroke limits must be more than 15 degrees apart.	Move the actuator in the clockwise / counterclockwise direction to increase the span of these limits. Choose one of the following: <ol style="list-style-type: none"> 1. Move the second actuator stroke limit and attempt to program the new position. 2. Press and hold the ERASE button to erase existing data and set new positions for the first and second actuator stroke limits.
3 Blinks (Setting first modulation limit)	13	Modulation limit is beyond or too close to one of the actuator stroke limits. The limit must be more than one degree away from the actuator stroke limits .	Move the actuator in the appropriate direction to ensure that the current actuator position is within the actuator stroke limits and more than one degree away from the actuator stroke limit.
	14		
2 Blinks (Setting second modulation limit)	15	The 4-20 mA modulation limits are too close. The 4-20 mA modulation limits must be separated by more than 13 degrees.	Move the actuator in the appropriate direction to increase the span of these limits. Choose one of the following: <ol style="list-style-type: none"> 1. Move the second modulation limit and attempt to program the new position. 2. Press and hold the ERASE button to erase existing data and set new positions for the first and second modulation limits
	16	Minimum and Maximum Firing Rate values are too close. Must be separated by more than 3 mA.	Increase the span of the Firing Rate input: <ol style="list-style-type: none"> 1. Ensure that the 4 to 20 mA input is correctly connected. 2. If the 4 to 20 mA source is adjustable, choose one of the following: <ol style="list-style-type: none"> a. Increase the Second Firing Rate value and attempt to program the new position. b. Press and hold the Erase button to erase existing data and set new positions for the Modulation Limits and Firing Rate values.
	19	The firing rate input value is too low. The minimum allowable firing rate is 3 mA.	Increase the firing rate value. Ensure that the 4-20 mA source is properly connected and functioning correctly.
	21	The firing rate input value is too high. The maximum allowable firing rate is 22.5 mA.	Decrease the firing rate value. Ensure that the 4-20 mA source is properly connected and functioning correctly.

Table 4. Fault listings and descriptions .

Fault/ Blink Code	Description	Corrective Action
29	Internal error—ISR check.	Reset control. ^a
31	Internal fault—A2D Range.	Reset control. ^{a,c}
58	Stuck Program button.	Check for stuck button.
59	Stuck Erase button.	Check for stuck button.
64	Internal memory fault.	Reset control. ^a Reprogram the actuator.
71	Motor offline.	Reset control. Check actuator wiring and for stuck damper/ valve. ^{b,c}
82	Motor speed too slow.	Check for stuck damper/valve. ^{b,c}
83	Actuator nonresponsive.	Check actuator wiring and stuck damper/valve. ^{b,c}

^a It is possible that a random external electrical noise has caused a fault checking algorithm to be detected. Resetting the actuator (press and hold both PROGRAM and ERASE buttons) will allow recalculation of the fault and, if it is not a hard failure, the device will continue to operate. If the condition will not clear, the device must be replaced.

^b Verify actuator total resistance and wiper measurements; check the ability of the actuator to travel full stroke using the manual override buttons in the actuator. Verify input power to the actuator. If the actuator is not functioning, replace the actuator.

^c Make sure that all internal plug-in headers are properly seated.

NOTE: The ML7999B will clear all lockout conditions and attempt a restart by itself every 60 seconds (Except for faults 64 and 71).

Honeywell

Automation and Control Solutions

Honeywell
1985 Douglas Drive North
Golden Valley, MN 55422

Honeywell Limited-Honeywell Limitée
35 Dynamic Drive
Scarborough, Ontario
M1V 4Z9

Honeywell International

Control Products
Honeywell Building
17 Changi Business Park Central 1
Singapore 486073

Honeywell Europe S.A.

3 Avenue du Bourget
1140 Brussels
Belgium

Honeywell Latin American Region

480 Sawgrass Corporate Parkway
Suite 200
Sunrise FL 33325

